

# Outdoor Unit Multi-zone Heat Pump Ductless System



Outdoor Model: **38MGRQ18B--3**

## Submittal Data

Job Data:  Location:

Buyer:  Buyer P.O. #:  Carrier #:

Unit Number:  Model Number:

Performance Data Certified By:  Date:

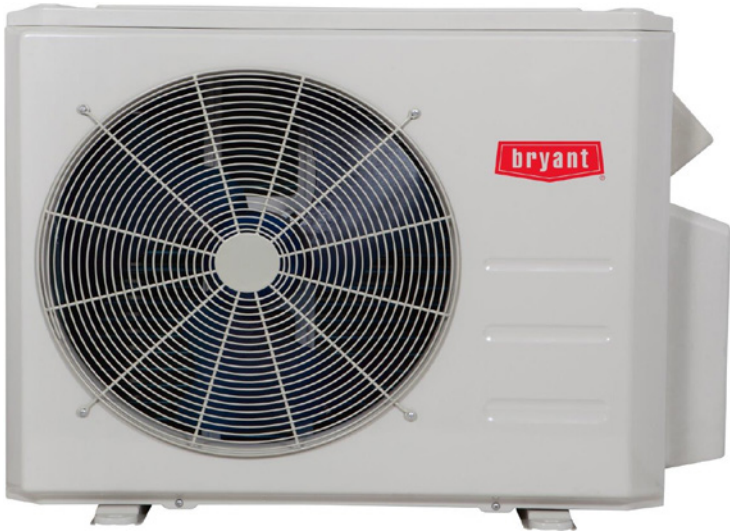

### MULTI-ZONE STANDARD FEATURES

Features Outdoor:

- Connect 2, multiple style indoor units
  - High Wall
  - Cassette
  - Ducted
  - Floor Console
- Variable Speed (Inverter) Compressor
- Basepan Heater factory installed
- Quiet operation
- Aluminum Blue Hydrophilic pre-coated fins

Cooling operating range -13°~122° F (-25°~50° C)  
 Heating operating range -22°~86° F (-30°~30° C)

LIMITED WARRANTY\*

- 10 year limited to original purchaser on compressor and parts upon timely registration, otherwise 5 years
- \*For residential applications. See warranty for full details.



**Preferred**<sup>TM</sup>  
**SERIES**

### Compatibility Table

INDOOR UNIT			OUTDOOR UNIT
			38MGRQ18B--3
High Wall	619PHAQ09XA3		•
	619PHAQ12XA3		•
	619PEQ009BBMA		•
	619PEQ012BBMA		•
	40MHHQ09---3		•
	40MHHQ12---3		•
Cassette	619REQ009CBMA	40MBCQ09---3	•
	619REQ012CBMA	40MBCQ12---3	•
Ducted	619REQ009DBMA	40MBDQ09---3	•
	619REQ012DBMA	40MBDQ12---3	•
Floor Console	619REQ009FBMA	40MBFQ09---3	•
	619REQ012FBMA	40MBFQ12---3	•

# Specifications

System	Size	18	
	Outdoor Model	38MGRQ18B--3	
	Max Number of Zones	2	
Performance Non-Ducted	Energy Star	YES	
	Cooling System Tons	1.5	
	Cooling Rated Capacity	Btu/h	18,000
	Cooling Cap. Range Min - Max	Btu/h	5810~21940
	SEER	22.5	
	EER	12.5	
	Heating Rated Capacity (47°F)	Btu/h	19,000
	Heating Maximum Capacity (5°F)	Btu/h	13,900
	Heating Cap. Range Min - Max	Btu/h	5760~24480
	HSPF	10.3	
	COP (47°F)	W/W	3.6
COP (5°F)	W/W	2.15	
Performance Combination Ducted and Non-Ducted	Energy Star	NO	
	Cooling System Tons	1.5	
	Cooling Rated Capacity	Btu/h	18,000
	Cooling Cap. Range Min - Max	Btu/h	5795~20708
	SEER	20.45	
	EER	12.15	
	Heating Rated Capacity (47°F)	Btu/h	18,750
	Heating Maximum Capacity (5°F)	Btu/h	14,150
	Heating Cap. Range Min - Max	Btu/h	5650~24365
	HSPF	9.85	
	COP (47°F)	W/W	3.7
COP (5°F)	W/W	2.125	
Performance Ducted	Energy Star	NO	
	Cooling System Tons	1.5	
	Cooling Rated Capacity	Btu/h	18,000
	Cooling Cap. Range Min - Max	Btu/h	5780~19476
	SEER	18.4	
	EER	11.8	
	Heating Rated Capacity (47°F)	Btu/h	18,500
	Heating Maximum Capacity (5°F)	Btu/h	14,400
	Heating Cap. Range Min - Max	Btu/h	5539~24249
	HSPF	9.4	
	COP (47°F)	W/W	3.8
COP (5°F)	W/W	2.1	

Operating Range	Cooling Outdoor DB Min - Max	°F(°C)	-13~122 (-25~50)
	Heating Outdoor DB Min - Max	°F(°C)	-22~86 (-30~30)
Piping	Total Piping Length	ft (m)	131(40)
	Piping to furthest FCU	ft (m)	82 (25)
	Drop (OD above ID)	ft (m)	49(15)
	Lift (OD below ID)	ft (m)	49(15)
	Pipe Connection Size - Liquid	in (mm)	1/4*2(6.35*2)
	Pipe Connection Size - Suction	in (mm)	3/8*2(9.52*2)
Refrigerant	Type	R410A	
	Charge	lbs (kg)	4.41 (2.0)
	Metering Device	EEV	
Electrical	Voltage, Phase, Cycle	V/Ph/Hz	208/230-1-60
	Power Supply	Indoor unit powered from outdoor unit	
	MCA	A.	18
	MOCP - Fuse Rating	A.	25
Compressor	Type	R410A	
	Model	ATM150D23UFZ	
	Oil Type	ESTER OIL VG74	
	Oil Charge	Fl. Oz.	17.64
	Rated Current	RLA	10
Outdoor	Unit Width	in (mm)	37.31 (948)
	Unit Height	in (mm)	27.64 (702)
	Unit Depth	in (mm)	14.82 (376)
	Net Weight	lbs (kg)	105.8 (48)
	Airflow	CFM	1390
	Sound Pressure	dB(A)	62.4

# Construction View

Outdoor Model: 38MGRQ18B--3

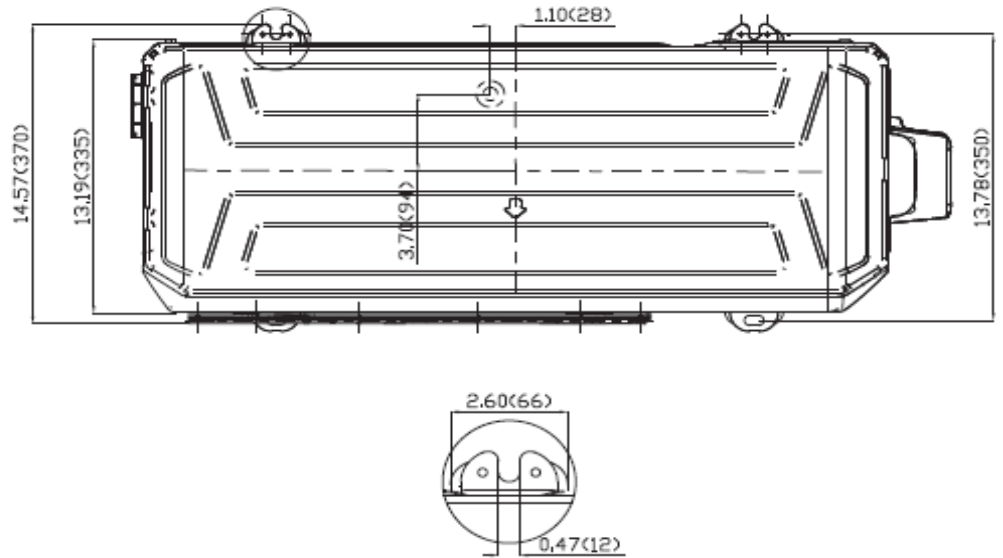
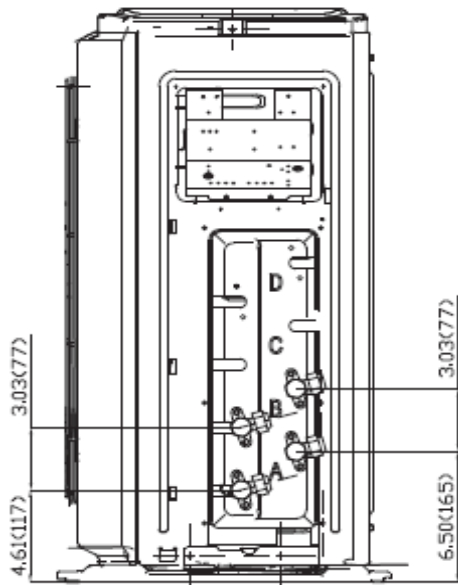
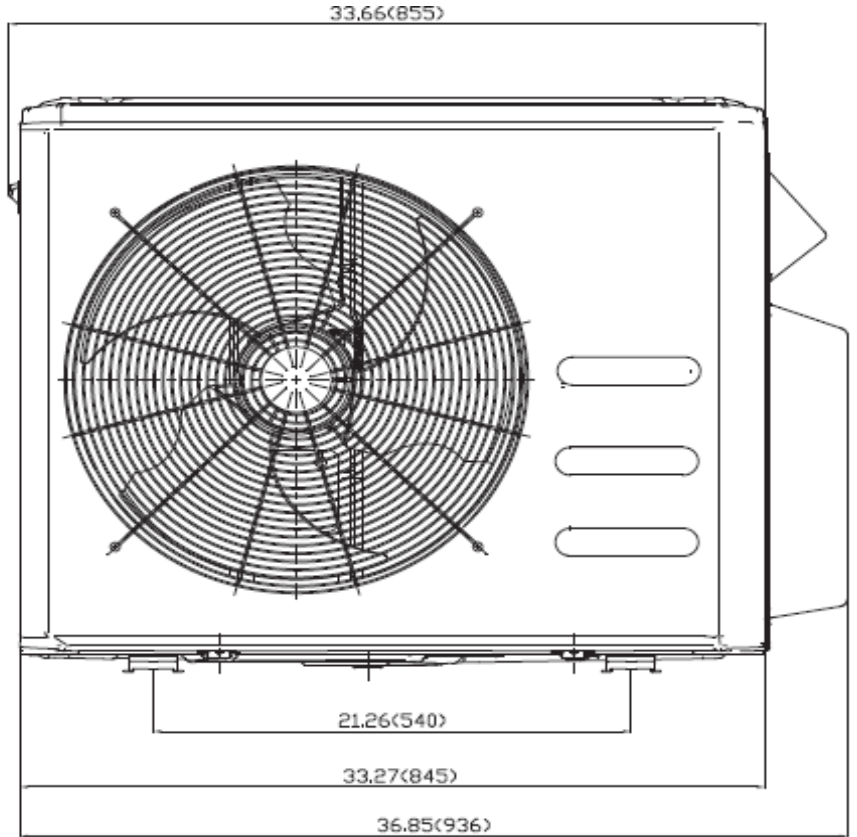
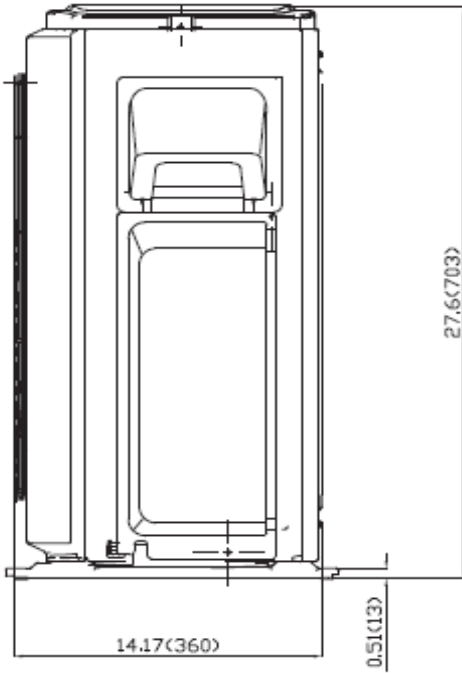

**NOTE: Master valves are not available on the size 18 unit.**

